

Alwayse Euro Units have a main bearing cup of special toughened steel with a dirt exit hole and a woollen felt seal.

Min. -30°C to max. +70°C continuous, or +100°C intermittent. Special seals may need to be fitted to suit extreme conditions. In clean conditions and without seals +150°C to +200°C are possible, using Type 15 units at reduced loads.

MATERIAL SPEC:

Stainless Steel Pressings AISI 304
 Stainless Steel Balls AISI 420
 Nylon Balls NYLON 66

EURO 0

Features: Various fixing clips available, dimensionally compatible with the 800 series, see pages 18 & 19.

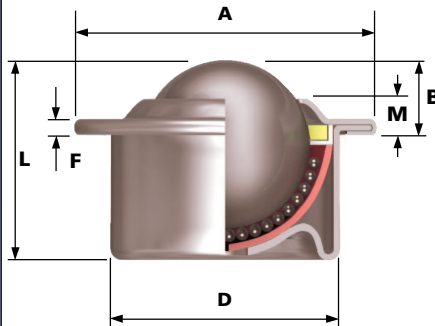

EURO 1

Features: Pop rivet or screw fixing.

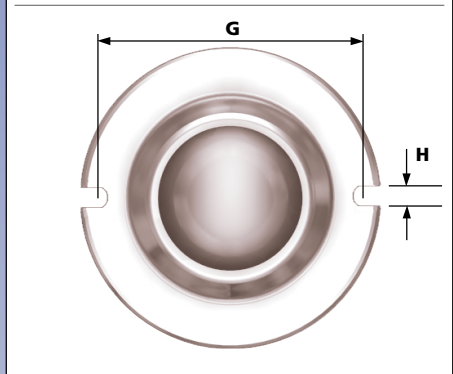
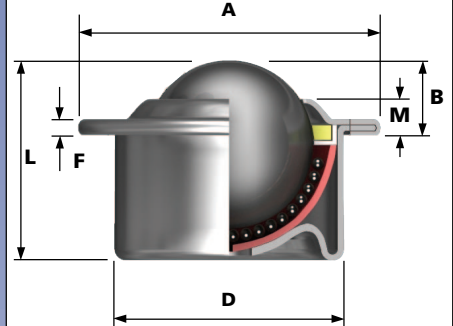

EURO 2

Features: Easy fitting with a 3 prong built-in clip from top face of ball table, compact and low profile, dimensionally identical to other Euro Unit ball units

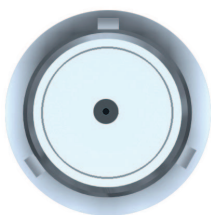
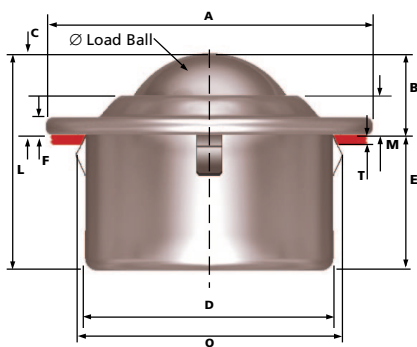

EURO 4

Features: Various fixing clips available, coned outer ring. Dimensionally compatible with the 800 series, see pages 18 & 19.

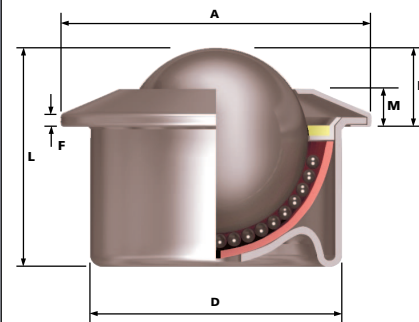

EURO 6

Features: Various fixing clips available. Reinforced coned outer ring and support cup for improved protection against shock loading. Dimensionally compatible with the 800 series. Woollen felt seals are standard except for the 515-6 ball unit.

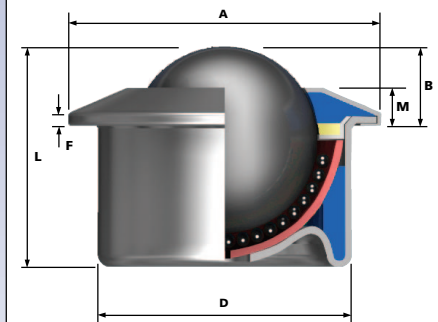

REF No.	BALL SIZE (mm)	DIMENSIONS (mm)							
		A	B	D	F	G	H	M	L
		Maximum Diameter	Working Height of Ball	Body Diameter	Flange Thickness	P.C.D. or Centres of Fixing Slots	Hole Diameter of Fixing Slots	Under Flange to Top of Outer Ring	Overall Height
515-0	15.8	31	9.5 ±0.2	24 ±0.065	2.8	-	-	6.3	21
515-1						29 ±0.2	3.5		
515-4						-	-		
515-6						-	-		
522-0	22.2	45	9.8 ±0.2	36 ±0.08	2.8	-	-	5.5	30
522-1						42 ±0.2	3.5		
522-4						-	-		
522-6						-	-		
530-0	30	55	13.8 ±0.3	45 ±0.08	4	-	-	8.3	37
530-1						51 ±0.2	3.5		
530-4						-	-		
530-6						-	-	8	
545-0	44.5	75	19 ±0.4	62 ±0.095	4	-	-	10	53.5
545-1						69 ±0.2	4.3		
545-4						-	-		
545-6						-	-		

MAXIMUM DYNAMIC LOADING (kg)							
TYPE 13		TYPE 14		TYPE 15		TYPE 16	
Carbon Steel Bearings, Zinc Plated Pressings		Nylon Load Bearing, Zinc Plated Pressings		Stainless Steel Bearings and Pressings		Stainless Steel Bearings, Zinc Plated Pressings	
WEIGHT (KGS)	CAPACITY (kg)	WEIGHT (KGS)	CAPACITY (kg)	WEIGHT (KGS)	CAPACITY (kg)	WEIGHT (KGS)	CAPACITY (kg)
0.043	60	0.028	10	0.043	38	0.043	60
0.043	60	0.028	10	0.043	38	0.043	60
0.043	60	0.028	10	0.043	38	0.043	60
0.054	60	0.039	10	0.054	38	0.054	60
0.132	160	0.096	20	0.132	100	0.132	160
0.132	160	0.096	20	0.132	100	0.132	160
0.132	160	0.096	20	0.132	100	0.132	160
0.165	160	0.130	20	0.165	100	0.165	160
0.278	300	0.182	25	0.278	200	0.278	300
0.278	300	0.182	25	0.278	200	0.278	300
0.278	300	0.182	25	0.278	200	0.278	300
0.335	300	0.238	25	0.335	200	0.335	300
0.725	610	-	-	0.725	250	0.725	610
0.725	610	-	-	0.725	250	0.725	610
0.725	610	-	-	0.725	250	0.725	610
0.887	610	-	-	0.887	250	0.887	610

REF No.	LOAD BALL SIZE (mm)	DIMENSIONS (mm)									
		A	B	C	D	E	F	M	L	O	T
		Maximum Diameter (mm)	Working Height of Ball (mm)	Ball Exposure (mm)	Body Diameter (mm)	Distance from under Flange to Base (mm)	Flange Thickness (mm)	Under Flange to top of Outer Ring (mm)	Overall Length (mm)	Seating Hole Diameter (mm)	Table Top Material Thickness (mm)
515-2	15.8	31	9.5 ±0.2	3.2	24 ±0.1	11.5	2.8	6.3	21	25.0 25.5	2
522-2	22.2	45	9.8 ±0.2	4.3	36 ±0.1	20.2	2.8	5.5	30	37.0 37.5	3
530-2	30	55	13.8 ±0.2	5.5	45 ±0.1	23.2	4	8.3	37	46.0 46.5	6
545-2	44.5	75	19 ±0.2	9	62 ±0.1	34.5	4	10	53.5	63.0 63.5	7

MAXIMUM DYNAMIC LOADING (kg)							
TYPE 13		TYPE 14		TYPE 15		TYPE 16	
Carbon Steel Bearings, Zinc Plated Pressings		Nylon Load Bearing, Zinc Plated Pressings		Stainless Steel Bearings and Pressings		Stainless Steel Bearings, Zinc Plated Pressings	
WEIGHT (KGS)	CAPACITY (kg)	WEIGHT (KGS)	CAPACITY (kg)	WEIGHT (KGS)	CAPACITY (kg)	WEIGHT (KGS)	CAPACITY (kg)
0.043	60	0.028	10	0.043	38	0.043	60
0.132	160	0.096	20	0.132	100	0.132	160
0.278	300	0.182	25	0.278	200	0.278	300
0.725	610	-	-	0.725	250	0.725	610

To order, specify REF N° and TYPE, i.e 515-0-13.

For load down use as a castor, reduce dynamic load rating by 50%.

CL14 FIXING CLIPS (Please see pages 30 and 31 for CL14 fixing clip dimensions)

REF No.	SUITABLE FOR UNITS
CL14-515	515-0, 515-4, 515-6
CL14-522	522-0, 522-4, 522-6
CL14-530	530-0, 530-4, 530-6
CL14-545	545-0, 545-4, 545-6

To order, specify REF N°, i.e CL14-515.

FIXING HOLE SIZES (mm)	
24	+1.0 +1.5
36	+1.0 +1.5
45	+1.0 +1.5
62	+1.0 +1.5

General Tolerance unless stated ±0.3mm